

TITLE 14 – FIRE CODE

BILL NO. \_\_\_\_\_

INTRODUCED BY COUNCIL

ORDINANCE NO. \_\_\_\_\_

**AN ORDINANCE AMENDING CHAPTER 14 OF THE SPARKS MUNICIPAL CODE, FIRE PREVENTION AND PROTECTION, TO MORE CLOSELY CONFORM TO THE 2018 INTERNATIONAL FIRE CODE AND TO ADD THE 2018 INTERNATIONAL WILDLAND-URBAN INTERFACE CODE; AND PROVIDING OTHER MATTERS PROPERLY RELATED THERETO.**

**THE CITY COUNCIL OF THE CITY OF SPARKS DOES ORDAIN:**

**SECTION 1.** Section 14.04.005: “Fire code transition” is hereby amended as follows:

**Section 14.04.005 - Fire code transition.**

~~Chapter 14.04 is repealed in its entirety, effective July 1, 2005.~~

~~An applicant for a building permit who submits his or her completed building permit application to the City of Sparks prior to July 1, 2005, may comply with any of the City's applicable fire code provisions under provisions of SMC 14.04 or 14.05.~~

When adopted by Sparks City Council, an applicant who submits his or her completed building permit application to the City of Sparks prior to July 1, 2019, may comply with any of the City's applicable fire code provisions under SMC 14.04 or 14.05.

**SECTION 2.** Section 14.05.0010: “Adoption” is hereby amended as follows:

**Section 14.05.0010 – Adoption.**

~~That a~~Those certain documents, one (1) copy of each which ~~is~~are on file in the office of the City Clerk of the City of Sparks, being marked and designated as the International Fire Code, ~~2012–2018~~ edition, including Appendix Chapters ~~A–~~B, C, D & L as published by the International Code Council, except portions which are modified under or amended by provisions of this title, ~~and the 2012–2018 International Wildland-Urban Interface Code, except portions which are modified under or amended by provisions of this title, the 2018~~ Northern Nevada Fire Amendments, and the 2018 Northern Nevada Fire Amendments to the 2018 International Wildland-Urban Interface Code, as well as all sections that reference the International Plumbing Code, shall be amended to reference the Uniform Plumbing Code, be and ~~is~~are hereby adopted as the Fire Code of the City of Sparks, in the State of Nevada regulating and governing the safeguarding of life and property from fire and explosion hazards arising from the storage, handling and use of hazardous substances, materials and devices, and from conditions hazardous to life or property in the occupancy of buildings and premises as herein provided; providing for the issuance of permits and collection of fees therefor; and each and all of the regulations, provisions, penalties, conditions and terms of said fire code on file in the office of the City Clerk

## TITLE 14 – FIRE CODE

are hereby referred to, adopted, and made a part hereof, as if fully set out in this chapter, with the additions, insertions, deletions and changes, if any, prescribed in this chapter.

**SECTION 3.** Section 14.05.0100: “Chapter 1—Administration” is hereby amended as follows:

### **Section 14.05.0100 – Chapter 1—Administration.**

Chapter 1 of the ~~2012-2018~~ Edition of the International Fire Code is amended to read as follows:

#### ***SECTION 101 – GENERAL***

##### **101.1 Title.**

These regulations shall be known as the Fire Code of the City of Sparks Fire Department, hereinafter referred to as "this code".

##### **102.7 Referenced codes and standards.**

The codes and standards referenced in this code shall be ~~those the most current~~ that are listed in Chapter 80 ~~except that the most current version of each of those codes and standards apply. Such codes and standards shall be considered part of the requirements of this code to the prescribed extent of each such reference. Where differences occur between the provisions of this code and the referenced standards, the provisions of this code shall apply.~~

#### ***SECTION 103 - DEPARTMENT OF FIRE PREVENTION***

##### **103.3.1 Deputies.**

The Fire Prevention Division will be staffed in accordance with the policies of the City of Sparks and shall have the powers of police officers to carry out the provisions of this code.

#### ***SECTION 104 - GENERAL AUTHORITY AND RESPONSIBILITIES***

##### **104.10.2 Physical evidence.**

If it appears that a fire is of accidental, natural, or incendiary origin, the Fire Official conducting the investigation is authorized to take immediate charge of all physical evidence relating to the cause of the fire.

## TITLE 14 – FIRE CODE

### ***SECTION ~~109-110~~ – VIOLATIONS***

#### **109.4110.4 Violation penalties.**

Persons who violate a provision of this code or fail to comply with any of the requirements thereof, or who erect, install, alter, repair, or do work in violation of the approved construction documents or directives of the fire code official, or of a permit or certificate used under the provisions of this code, shall be guilty of a misdemeanor. Each day that a violation continues after due notice has been served shall be deemed a separate offense.

### **SECTION 111 – UNSAFE BUILDINGS**

#### **111.5 Structure unfit for human occupancy.**

A structure is unfit for human occupancy whenever the city official finds that such structure is unsafe, unlawful or, because of the degree to which the structure is in disrepair or lacks maintenance, is insanitary, vermin or rat infested, contains filth and contamination, or lacks ventilation, illumination, sanitary or heating facilities or other essential equipment required by this code, or because the location of the structure constitutes a hazard to the occupants of the structure or to the public. Persons so notified shall immediately leave the structure or premises and shall not enter or re-enter until authorized to do so by the city official or the city official in charge of the incident.

#### **111.6 Dangerous structure or premises.**

A building or structure, used or intended to be used for dwelling purposes, because of inadequate maintenance, dilapidation, decay, damage, faulty construction or arrangement, inadequate light, ventilation, mechanical or plumbing system, or otherwise, is determined by the city official to be unsanitary, unfit for human habitation or in such a condition that is likely to cause sickness or disease. Persons so notified shall immediately leave the structure or premises and shall not enter or re-enter until authorized to do so by the city official or the city official in charge of the incident.

### ***SECTION ~~111-112~~ - STOP WORK ORDER***

#### **111.4112.4 Failure to comply.**

Any person who shall continue any work after having been served with a stop work order, except such work as that person is directed to perform to remove a violation or unsafe condition, shall be guilty of a misdemeanor.

## TITLE 14 – FIRE CODE

**SECTION 4.** Section 14.05.0200: “Chapter 2—Definitions” is hereby amended as follows:

### **Section 14.05.0200 - Chapter 2—Definitions.**

Chapter 2 of the ~~2012-2018~~ Edition of the International Fire Code is amended to read as follows:

#### ***SECTION 201 – GENERAL***

##### **201.3 Terms defined in other codes.**

Where terms are not defined in this code and are defined in the International Building Code, International Fuel Gas Code, International and Uniform Mechanical Code, ~~or~~ Uniform Plumbing Code, ~~2012-2018 International Wildland-Urban Interface Code, 2018 Northern Nevada Fire Amendments, or 2018 Northern Nevada Fire Amendments to the 2018 International Wildland-Urban Interface Code,~~ such terms shall have the meanings ascribed to them as in those codes.

#### ***SECTION 202 - GENERAL DEFINITIONS***

##### **202 Occupancy Classification Group A-2.**

Casino

**CASINO.** Any building or structure with an assembly Group A Occupancy at which gaming is licensed under applicable state and local laws.

**SECTION 5.** Section 14.05.0500: “Chapter 5 – Fire Service Features” is hereby added as follows:

### **Section 4.14.05.0500 – ~~Reserved.~~ Chapter 5 – Fire service features.**

**Editor's note**—~~Ord. No. 2479, § 6, adopted Sept. 9, 2013, repealed § 14.05.0500, entitled "Chapter 5 – Fire service features", which derived from Ord. 2266, adopted Feb. 28, 2005; and Ord. 2407, adopted Aug. 11, 2008.~~

#### ***SECTION 507 - PROTECTION WATER SUPPLIES***

##### **507.5.5 Clear space around hydrants.**

A clear space with a three-foot (3') radius will be maintained around all fire hydrants, except as otherwise required or approved. In addition, where physically possible, a minimum clear space of seven and one-half feet (7

# TITLE 14 – FIRE CODE

½’) shall be maintained on both sides of a hydrant as measured from the center of the hydrant. Where less than seven and one-half feet (7 ½’) of curbing exists, a minimum clear space of three feet (3’) on either side of the hydrant is required. In either case, the curb will be painted red to indicate no parking or other obstructions are allowed. See Exhibit #1-A and 1-B below.

Exhibit 1-A

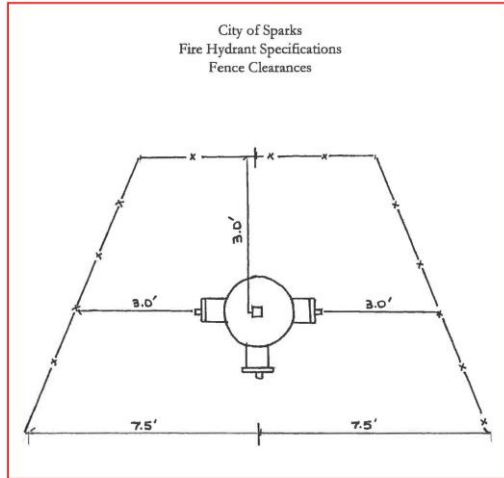
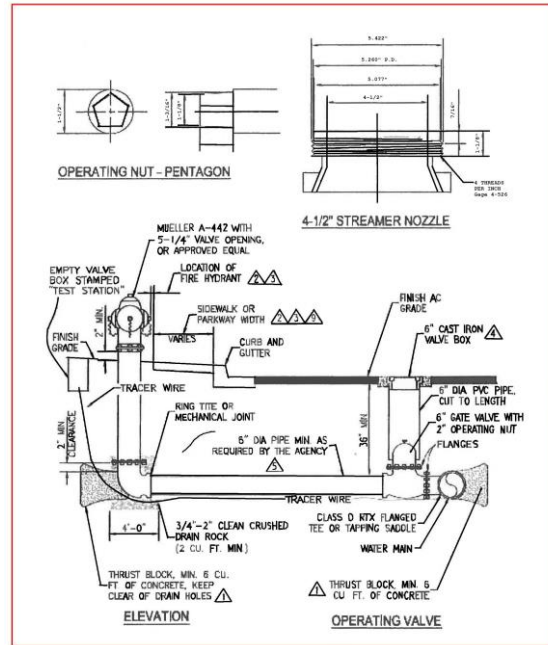

Exhibit 1-B



## TITLE 14 – FIRE CODE

### Fire Hydrant Notes:

1. Reinforced Portland cement concrete shall have the following characteristics: 4000 PSI minimum. Compressive strength @ 28 days, minimum, 6 sacks of cement per cubic yard with a maximum water/cement ratio of 0.45, Air entrainment 6% ± 1.5%, slump at 1 to 4 inches. All materials shall conform to SSPWC Section 202.
2. Fire hydrants shall be within 6 inches of the back edge of the sidewalk when the sidewalk is 5 feet or less in width. Contact the Fire Department for proper hydrant location if the sidewalks are wider than 5 feet.
3. When a landscape strip is between the curb and the sidewalk, or for curbs only, fire hydrants shall be 2 feet from the face of the curb.
4. Base shall be 6” minimum Type 2, Class B aggregate, compacted to a minimum 95% of maximum dry density.
5. Water pipe shall be ductile iron with field LOK gaskets.
6. Public hydrants shall be factory painted Sherwin Williams Yellow or equivalent.
7. Private hydrants shall be factory painted Sherwin Williams Red or equivalent.
8. All hydrants shall have two 2 ½” hose nozzles and one 4 ½” steamer nozzle.
9. No fences shall be allowed within 3 feet of any portion of a fire hydrant.
10. Curb shall be painted red in front of the fire hydrant in accordance with Sparks Municipal Code, Title 14.
11. All fire hydrants shall be tested, inspected, and approved by the Sparks Fire Department prior to combustible material being allowed on site.

**SECTION 6.** Section 14.05.0600: “Chapter 6 – Building services and systems” is hereby repealed in its entirety:

**SECTION 7.** Section 14.05.0900: “Chapter 9 – Fire protection systems” is hereby repealed in its entirety:

**SECTION 8.** Section 14.05.5410: “Appendix D – Fire Apparatus Access Roads” is hereby repealed in its entirety:

## TITLE 14 – FIRE CODE

**SECTION 9.** Section 14.16.010: “Violation – Penalty” is hereby amended as follows:

### **Section 14.16.010 - Violation—Penalty.**

- A. Any person who violates or fails to comply with any provisions of this title or any provisions of the Uniform-International Fire Code, International Wildland-Urban Interface Code, 2018 Northern Nevada Fire Amendments, or any order, rule or regulation made thereunder, is severally for each such violation and noncompliance guilty of a misdemeanor and shall be punished as provided in Section 1.12.010 of this code.
- B. The imposition of one penalty for any violation shall not excuse the violation or permit it to continue. All such persons shall be required to correct or remedy such violations or defects within a reasonable time, and, when not otherwise specified each five days that prohibited conditions are maintained constitutes a separate offense.
- C. The application of the penalty provided in this section shall not be held to prevent the enforced removal of prohibited conditions.

**SECTION 10.** All ordinances or parts of ordinances in conflict herewith are hereby repealed.

**SECTION 11.** The City Clerk is instructed and authorized to publish the title to this ordinance as provided by law.

**SECTION 12.** This ordinance shall become effective upon passage, approval and publication.

**SECTION 13.** The provisions of this ordinance shall be liberally construed to effectively carry out its purposes in the interest of the public health, safety, welfare and convenience.

**SECTION 14.** If any subsection, phrase, sentence or portion of this ordinance is for any reason held invalid or unconstitutional by any court of competent jurisdiction, such portion shall be deemed a separate, distinct and independent provision, and such holding shall not affect the validity of the remaining portions.

TITLE 14 – FIRE CODE

**SECTION 15.** The City Council finds that this ordinance is **not** likely to impose a direct and significant economic burden upon a business or directly restrict the formation, operation or expansion of a business, or is otherwise exempt from Nevada Revised Statutes Chapter 237.

**PASSED AND ADOPTED** this \_\_\_\_ day of \_\_\_\_\_, 20\_\_, by the following vote of the City Council:

**AYES:** \_\_\_\_\_

**NAYS:** \_\_\_\_\_

**ABSTAIN:** \_\_\_\_\_

**ABSENT:** \_\_\_\_\_

**APPROVED** this \_\_\_\_ day of \_\_\_\_\_, 20\_\_, by:

\_\_\_\_\_  
**RON SMITH, Mayor**

**ATTEST:**

\_\_\_\_\_  
**TERESA GARDNER, City Clerk**

**APPROVED AS TO FORM AND LEGALITY:**

\_\_\_\_\_  
**CHESTER H. ADAMS, City Attorney**